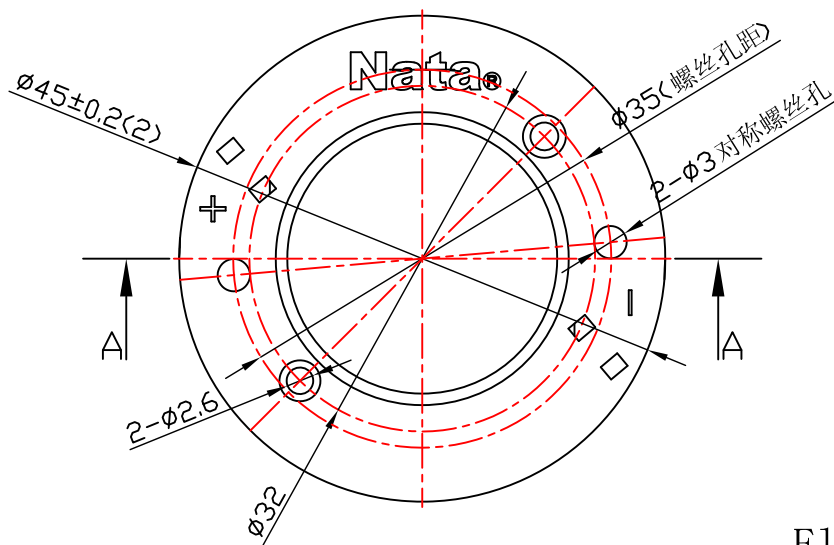
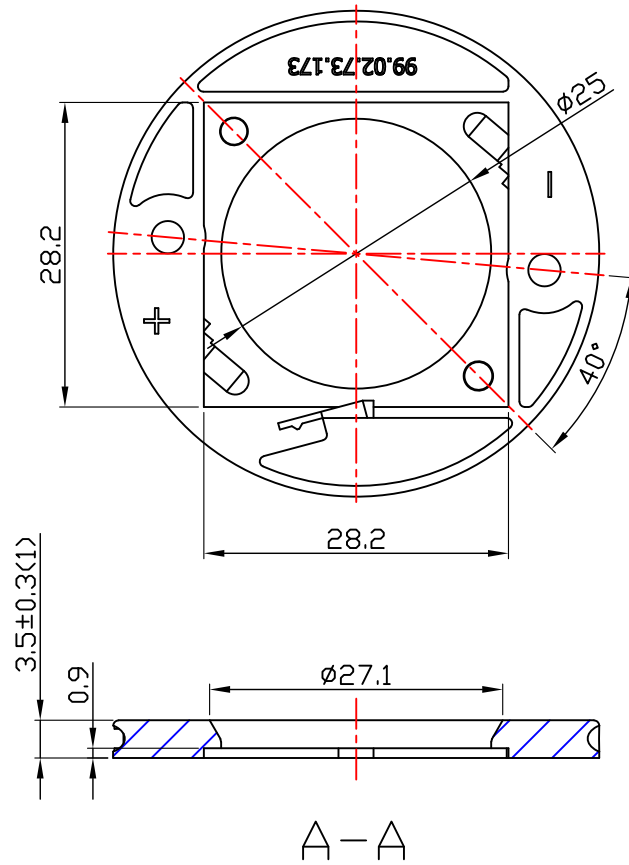



table for unmentioned tolerance in the drawing (unit: mm)					
0-5	5-30	30-120	120-250	250-400	400-700
±0.15	±0.2	±0.5	±0.8	±1.5	±2



Electric wires:
 $0.32\text{mm}^2 \sim 0.81\text{mm}^2$
 18AWG, 20AWG, 22AWG
 Tin plating after
 stripping 7mm

					Material: PBT		 NATA Lighting Co., Ltd	
Mark	Amended Times	Amended Content			Signature	Amended Date	Customer Item	
Control Version	A0	Design Version	K0	Client Version		Customer Code	NT	
Designer		Drawing by		Proportion	1:1	Product Number	99.02.73.173	
Technology		Auditor		View		Product Name	CLU04x免焊支架 D45xH3.5	
Approval		Date	2019.03.28	Page	Total_ Page_			